

# HH7E

Installation method		Application	
Floor	●	Spot welding	
Ceiling	●	Arc welding	
Wall surface		Handling	●
Angle	●	Assembly	●
		Sealing	●
		Painting	

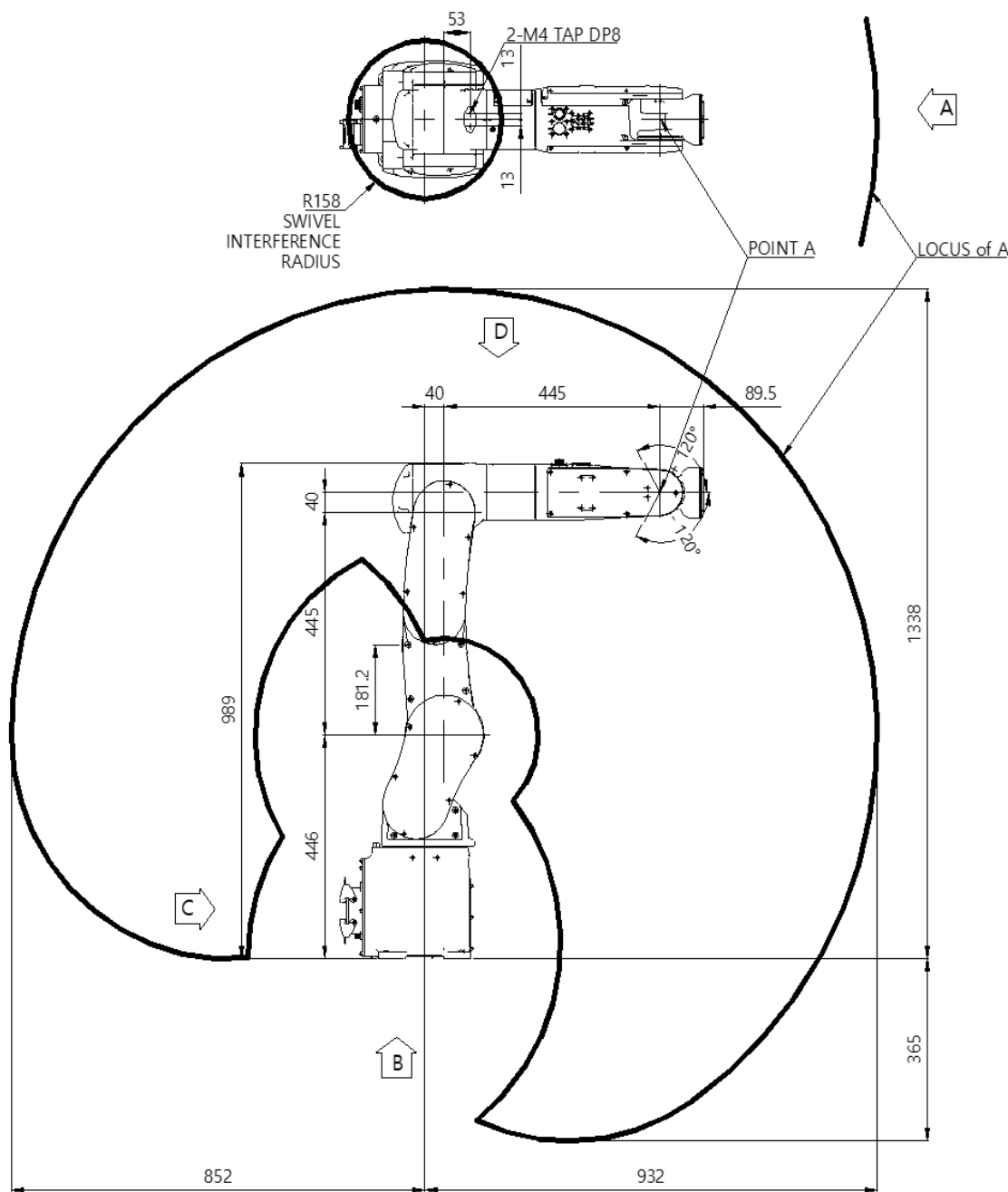

View A: Detailed drawing of the wrist attachment part

Item	Specification		
Robot model	HH7E		
Payload	7 Kg		
Structure	Articulated		
Degree of freedom	6 axes		
Drive system	AC SERVO MOTOR		
Max. working envelope	A	S Swivel	$\pm 2.967$ rad ( $\pm 170^\circ$ )
	r	H Horizontal	$+3.14 \sim -0.96$ rad ( $+180^\circ \sim -55^\circ$ )
		V Vertical	$+3.71 \sim -1.15$ rad ( $+213^\circ \sim -70^\circ$ )
		Wrist	R2 Rotation 2
	m*	B Bending	$\pm 2.094$ rad ( $\pm 120^\circ$ )
		R1 Rotation 1	$\pm 6.283$ rad ( $\pm 360^\circ$ )
Max. working speed	A	S Swivel	6.544 rad / s ( $375^\circ / s$ )
	r	H Horizontal	5.497 rad / s ( $315^\circ / s$ )
		V Vertical	7.155 rad / s ( $410^\circ / s$ )
		Wrist	R2 Rotation 2
	m*	B Bending	9.599 rad / s ( $550^\circ / s$ )
		R1 Rotation 1	13.613 rad / s ( $780^\circ / s$ )
Wrist torque	R2 Rotation 2	17 N.m (1.73 Kgf.m)	
	B Bending	17 N.m (1.73 Kgf.m)	
	R1 Rotation 1	10 N.m (1.02 Kgf.m)	
Accuracy of position repeatability	$\pm 0.02$ mm		
Ambient Temperature	0 ~ 45 °C (273 ~ 318 K)		
Robot's Weight	49 Kg		
Working envelope section area	1.98 m <sup>2</sup>		

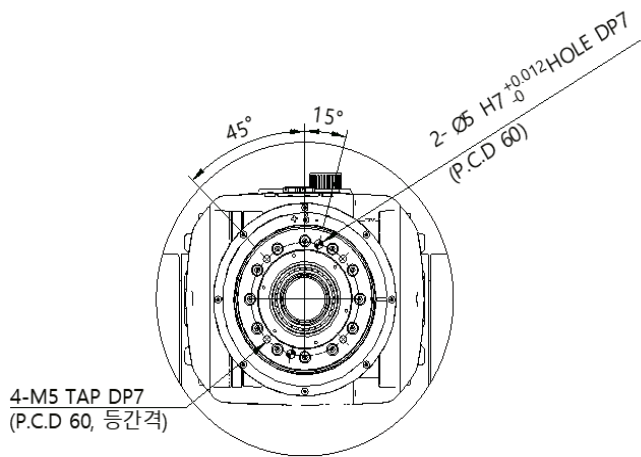

View B: Dimensional drawing for the floor installation of the body

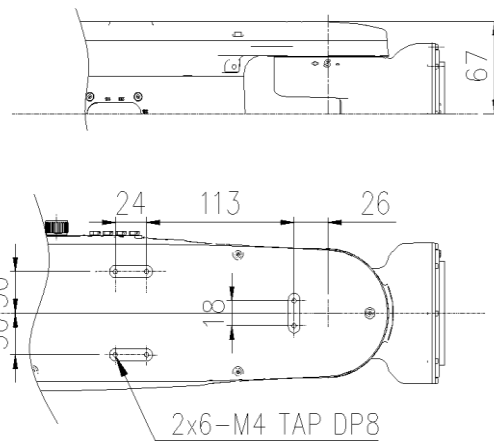

View G: Application part mounting

View C: Application cable connection part

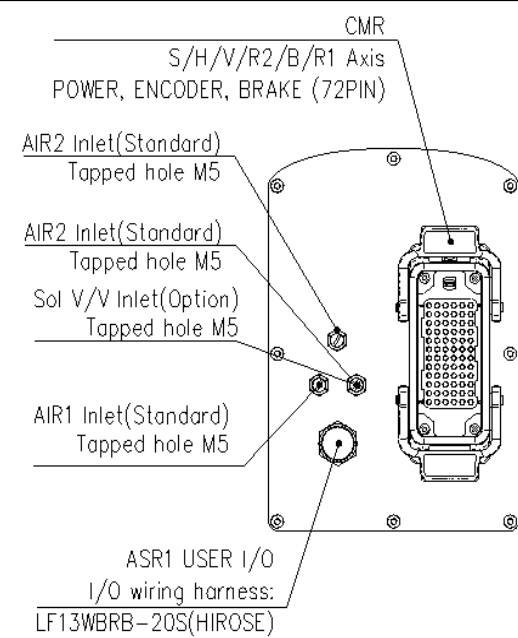

View D: Application cable connection part

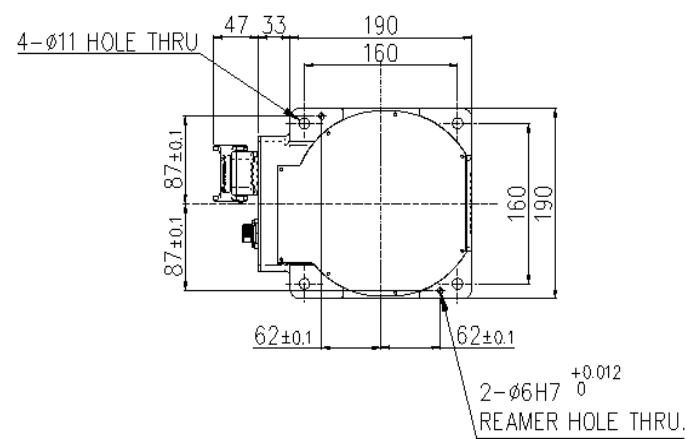
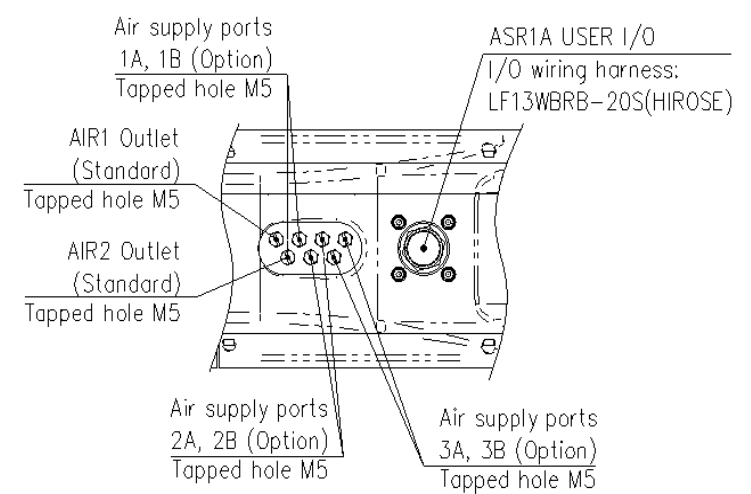

View E: Application part mounting

※ Precaution : When installing robot, please apply positioning pins. (2xØ6)

Wrist-axis torque line diagram

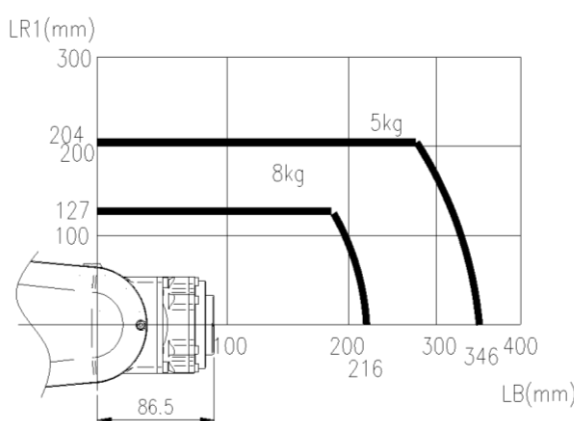

\*\* For product improvement, some of the ratings, specifications, dimensions, etc. are subject to changes without notice.